

**NOVOHALL
Rotary Sensor
touchless
transmissive**

Series RFX-6900



Special features

- Very robust design to extreme environmental conditions
- Touchless hall technology
- Electrical range up to 360°, in single and multi-channel version
- 2-part, mechanically decoupled
- Enhanced corrosion protection by anodized aluminum housing, salt spray resistant
- Very good linearity
- Resolution 12 bit
- Absolutely impermeable to splash-water IP6K9K
- High temperature resistance
- Suitable for use in safety-related applications according to ISO 13849
- For highest EMC requirements such as ISO pulses and interference fields according to ISO 11452 and ECE directive
- Customized versions

Applications

- Position measurement in steering systems
- Pivotable vehicle bracings
- Transport systems with several axes
- Construction and agricultural machinery

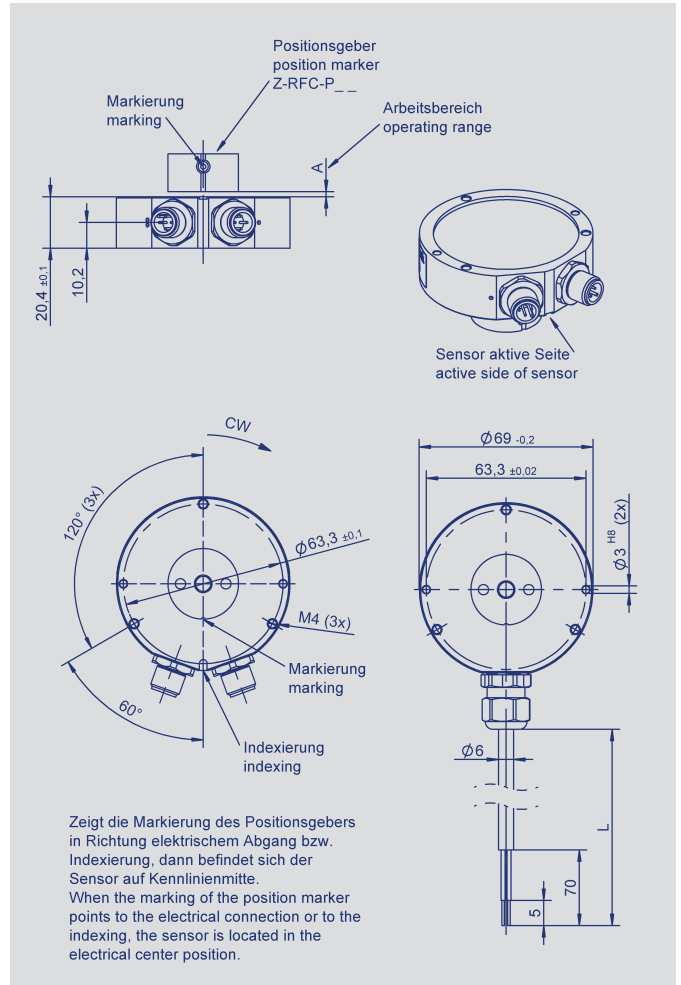

Description

Housing	Anodized aluminum, salt spray resistant
Electrical connections	Cable 4 x 0.5 mm ² , AWG 20, TPE, unshielded or connector M12x1, 4-pole

Inhalt

Mechanical Data	3
Characteristics	4
Technical Data Analog Interface	5
Ordering Specifications	6
Technical Data CANopen Interface	7
Ordering Specifications	8
Accessories	
Position marker / Sensor mounting	9
M8 Connector System	12

Mechanical Data

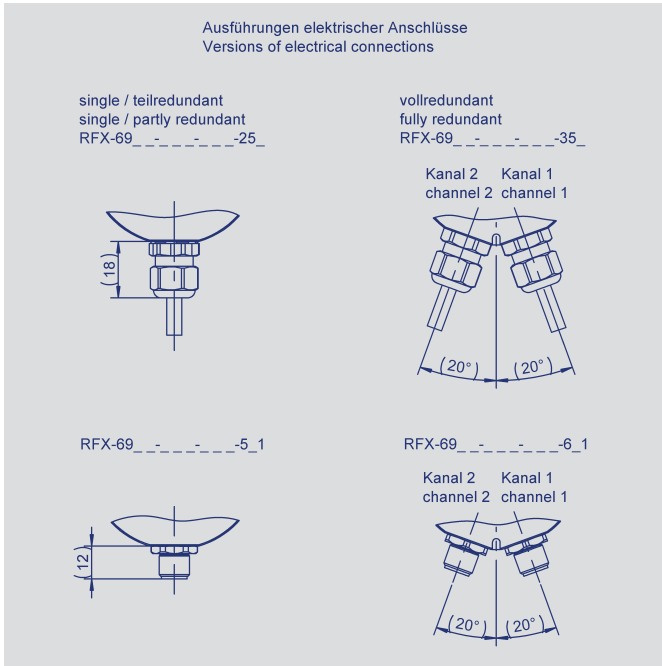

Mechanical data

Dimensions	see demision drawing	
Mounting	with 3 screws M4, screwing min. 7 mm	
Fastening torque of mounting screws	2.5 ±0.5	Nm
Mechanical travel	360 continuous	°
Maximum operational speed	mechanical unlimited	
Weight (without connection)	approx. 200	g
Environmental Data		
Operating temperature	-40...+85	°C
Vibration IEC 60068-2-6	5...2000 Amax = 0,75 amax = 20	Hz mm g
Shock IEC 60068-2-27	50 (6 ms)	g
Protection class (DIN EN 60529)	IP67 connector output M12 IP6K9K cable output	

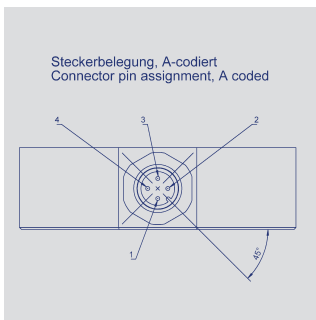

CAD data see
www.novotechnik.de/en/downloads/cad-data/

Characteristics

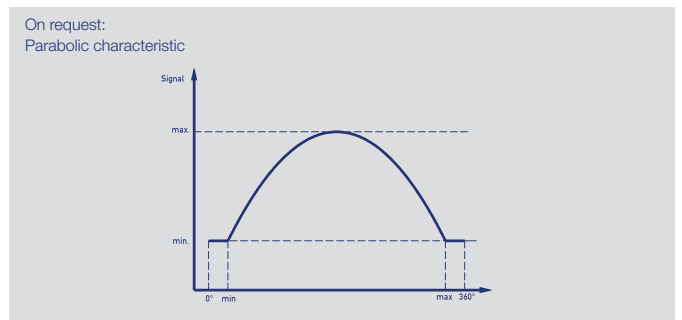
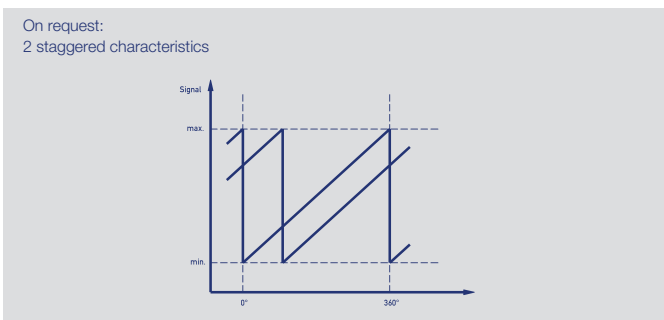
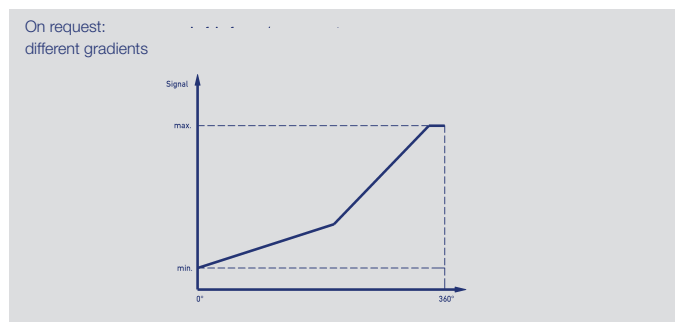
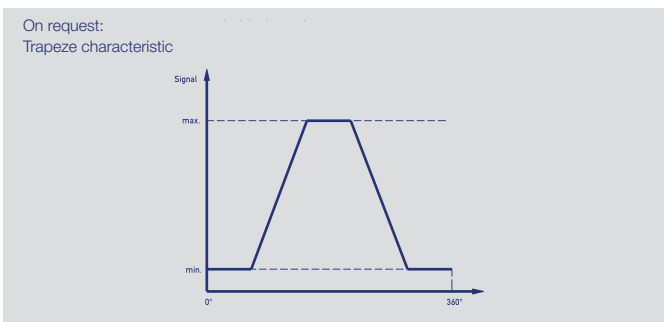
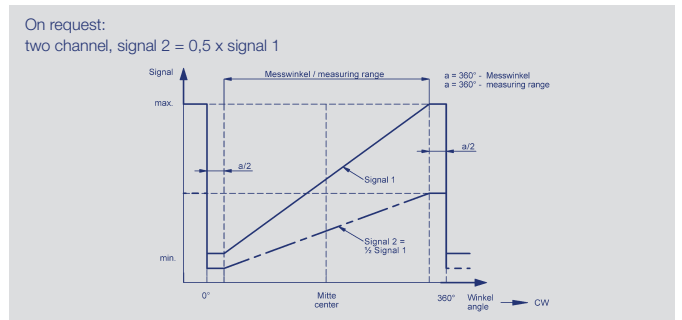
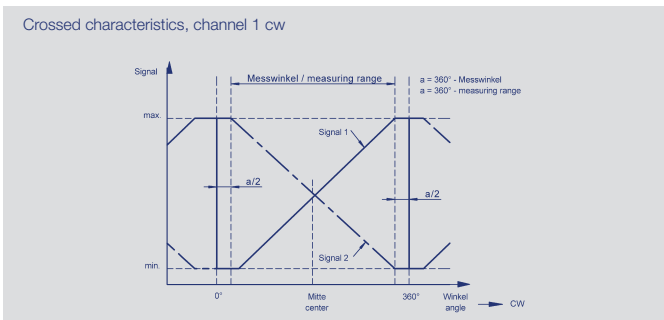
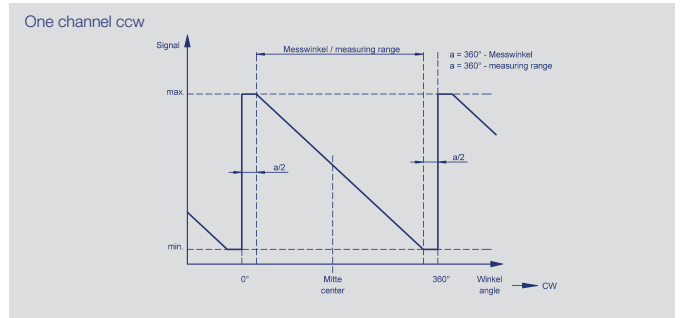
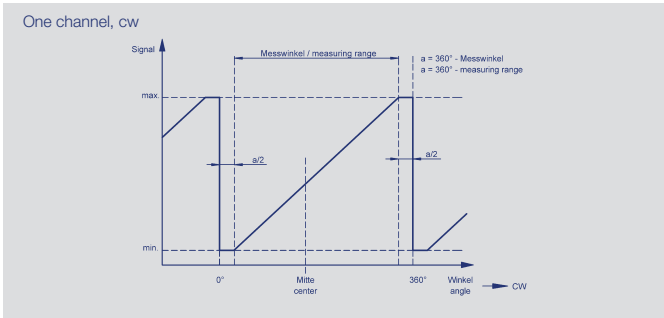

Technical Data
Analog Interface
- Current



Electrical Data	RFX-69 _ _ - _ _ - 32 _ - _ _ _ _ analog Current	
Output signal	4 ... 20 (burden max. 250 Ω, higher on request)	mA
Number of channels	1 / 2	
Update rate	5	kHz
Resolution	12	Bit
Measuring range	60, 120, 180, 240, 300, 360	°
Independent linearity	0.5	±%FS
Interlinearity channel 1 to channel 2 at measuring range < 90°	4.0	±%FS
Interlinearity channel 1 to channel 2 at measuring range ≥ 90°	2.0	±%FS
Repeatability	0.2	°
Hysteresis at measuring range < 360°	0.1	°
Hysteresis at measuring range 360°	0.25 (lower hysteresis on request)	°
Temperature error at measuring range < 90°	200	ppm/K
Temperature error at measuring range ≥ 90°	160	ppm/K
Supply voltage Ub	12/24 (9 ... 34)	VDC
Current consumption (w/o load)	typical 20 per channel, supply voltage Ub = 24 V	mA
Reverse voltage	yes	
Short circuit protection	yes, all oututs vs. GND and Ub	
Insulation resistance (500 VDC)	≥ 10	MΩ
Cross-section cable	0-5 (AWG 20)	mm ²
Environmental Data		
EMC compatibility	ISO 10605 Packaging und Handling + Component Test (ESD) 8 kV, 15 kV ISO 11452-2 Radiated EM HF-fields, Absorber hall 100 V/m ISO 11452-5 Radiated EM HF-fields, stripline 200 V/m CISPR 25 Radiated Emission, class 5 ISO 7637-2 Pulse 1, 2a, 2b, 3a, 3b, 4, 5 SG 4 ISO 7637-3 Transient emssion SG 4 Interference emission and immunity according to ECE-R10 (E1)	
Functional safety	Suitable for safety-relevant applications according to ISO 13849 after customer validation. Further safety data and support for functional safety are available on request.	
MTTF (DIN EN ISO 13849-1 - parts count method, w/o load, wc)	46 (per channel)	years
MTTFd (DIN EN ISO 13849-1 parts count method, w/o load, wc)	92 (per channel)	years
MTTF certificate s. https://www.novotechnik.de/en/downloads/certificates/mttfd-certificates/		

Single channel version

	Cable (Code -252)	M12 connector (Code -551)
Supply Ub	Green	Pin 1
GND	Brown	Pin 3
Signal	White	Pin 2
Not assigned	Yellow	Pin 4
Partly redundant version		
	Cable (Code -252)	M12 connector (Code -551)
Supply Ub	Green	Pin 1
GND	Brown	Pin 3
Signal 1	White	Pin 2
Signal 2	Yellow	Pin 4

Fully redundant version

	2 x cable (Code -352)	2 x M12 connector (Code -651)
Supply Ub 1	Channel 1 / Green	Channel 1 / Pin 1
GND 1	Channel 1 / Brown	Channel 1 / Pin 3
Signal 1	Channel 1 / White	Channel 1 / Pin 2
Supply Ub 2	Channel 2 / Green	Channel 2 / Pin 1
GND 2	Channel 2 / Brown	Channel 2 / Pin 3
Signal 2	Channel 2 / Yellow	Channel 2 / Pin 4
not assigned	Channel 1 / Yellow Channel 2 / White	Channel 1 / Pin 4 Channel 2 / Pin 2

Ordering Specifications Analog Interface - Current

Ordering specifications

Preferred types printed in bold

- Delivery time up to 25 pcs. within 10 working days EXW
- Best low-volume pricing

Supply Ub / interface
3: Ub = 12/24 V (9 ... 34 V)

Output signal
2: 4 mA ... 20 mA
Other characteristics on request

Output characteristic
1: rising CW
2: rising CCW
3: **Partly redundant version: crossed output channel 1 rising / channel 2 falling CW**
4: **Fully redundant version: crossed output channel 1 rising / channel 2 falling CW**
Other characteristics on request

Electrical connection
Single channel / partly redundant version: 1 output
252: 1 x cable 4-pole, 2 m, unshielded
551: 1 x connector M12, 4-pin, unshielded
Fully redundant version: 2 outputs
352: 2 x cable 4-pole, 2 m, unshielded
651: 2 x connector M12, 4-pin, unshielded
Cable versions and assembled connectors on request

R F X - 6 9 0 1 - 8 3 6 - 3 2 4 - 3 5 2

Series

Measuring range

06: 60°
12: 120°
18: 180°
24: 240°
30: 300°
36: 360°

Other angles on request

Number of channels

6: single channel version (1 x Ub, 1 x output)
7: partly redundant version (1 x Ub, 2 x output)
8: fully redundant version (2 x Ub, 2 x output)

Model / size
6901: 69 x 20.4 mm

Technical Data

CANopen®



Type Designations	RFX-69 __ -214-6 __ - __ - __ - CANopen	
Electrical Data		
Measured variables	Position and speed	
Measuring range	360	°
Measurement range speed	0 ... 1600	min-1
Number of channels	1 / 2	
Output signal / protocol	CANopen protocol to CiA DS-301 V4.2.0, Device profile DS-406 V3.2 Encoder Class C2, LSS services to CiA DS-305 V1.1.2	
Programmable parameter	Position, speed, cams, working areas, rotating direction, scale, offset, node-ID, baud rate	
Node-ID	1 ... 127 (default 127)	
Baud rate	50 ... 1000	kBaud
Resolution across 360° (position)	14	bit
Resolution speed	$360/2^{14} \approx 0.022$	°/ms
Update rate	1	kHz
Independent linearity	≤ 0.5	±% FS
Repeatability	≤ 0.36	°
Hysteresis	≤ 0.36	°
Temperature error	0.2	±% FS
Supply voltage U_b	12/24 (8 ... 34)	VDC
Current consumption (w/o load)	< 100	mA
Reverse voltage	yes, supply lines	
Short circuit protection	yes, output vs.GND and supply voltage U_b (up to 40 VDC)	
Overvoltage protection	< 45 (permanent)	VDC
Insulation resistance (500 VDC)	≥ 10	MΩ
Cross-section cable	0.5 (AWG 20)	mm ²
Bus termination internal	120, optionally	Ω
Environmental Data		
Operation temperature	-40 ... +105 (-25 ... +85 with M12 connector)	
MTTF (DIN EN ISO 13849-1 parts count method, w/o load, wc)	one-channel: 71 / two-channel: 58 (per channel)	
Functional safety	If you need assistance in using our products in safety-related systems, please contact us	
EMC compatibility	ISO 10605 Packaging and Handling + Component Test 8 kV ISO 11452-2 Radiated EM RF fields, Absorberhall 100 V/m ISO 11452-5 Radiated EM RF fields, Stripline 200 V/m CISPR 25 Radiated emission class 3 ISO 7637-2 Pulse 1, 2a, 2b, 3a, 3b, 4, 5 SG 3 ISO 7637-3 Transient transmission SG 4 EN 13309 Construction machinery Interference emission and immunity according to ECE-R10 (E1)	

Connection assignment

Signal	Cable Code 2 __ / 3 __	Connector M12 Code 5 __ / 6 __
CAN_SHLD	Shield	pin 1
Supply voltage U_b	WH	pin 2
GND	BN	pin 3
CAN_H	YE	pin 4
CAN_L	GN	pin 5

Cable shielding connect to GND.

Ordering Specifications



Ordering specifications

Preferred types printed in bold:

- Delivery time up to 25 pcs. within 10 working days EXW
- Best low-volume pricing

Interface

6: CANopen Interface

Interface parameters CANopen 6 _ _

- 1: 1 x position, 1 x speed**
- 2: 2 x position, 2 x speed**
- 5: 1 x position, 1 x speed with bus termination 120 Ω
- 6: 2 x position, 2 x speed with bus termination 120 Ω

Interface parameters IO-Link A _ _

- 11: 1 x position, rising cw**
- Other process data such as speed, revolution counter or cams on request

Baud rate

- 1: Baud rate 1000 kBaud**
- 2: Baud rate 800 kBaud**
- 3: Baud rate 500 kBaud**
- 4: Baud rate 250 kBaud**
- 5: Baud rate 125 kBaud**
- 7: Baud rate 50 kBaud**

Electrical connection

- 1 Output**
- 201: 1 x cable 4-pole 1.0 m, shielded
- 511: 1 x connector M12, 5-pole, shielded
- 2 Outputs (CAN IN/OUT)**
- 301: 2 x cable 4-pole 1.0 m, shielded
- 611: 2 x connector M12, 5-pole, shielded

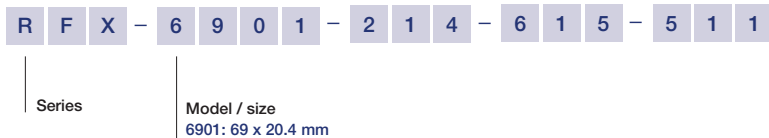

Position Marker Mounting Material

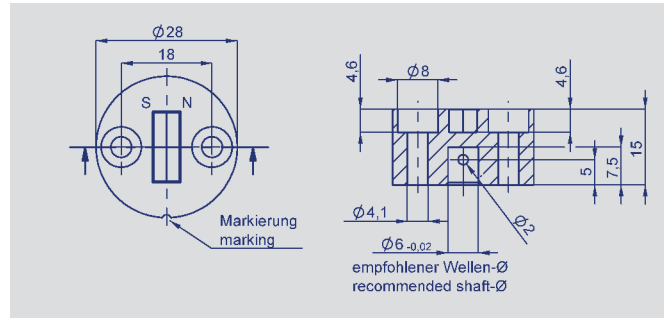
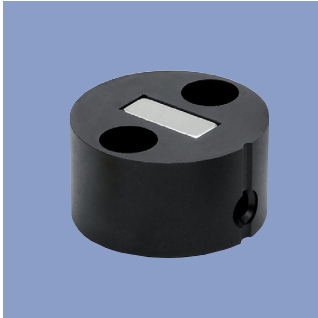

Z-RFC-P02

Position marker for frontal fixation with 2 cylinder head screws M4x20 (with microencapsulation) or with locking pin

- (both included in delivery)
- max. permitted radial offset ± 3 mm
- packaging unit:
1 pc. P/N 400005661
25 pcs. P/N 400056080

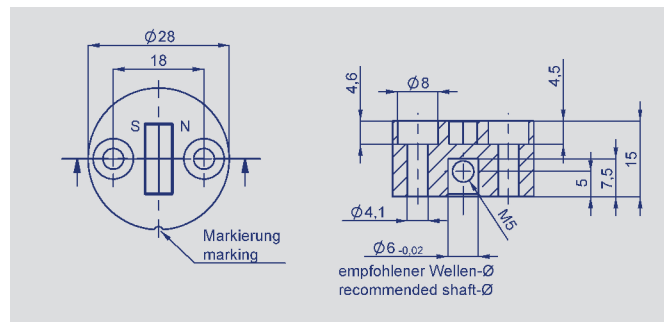
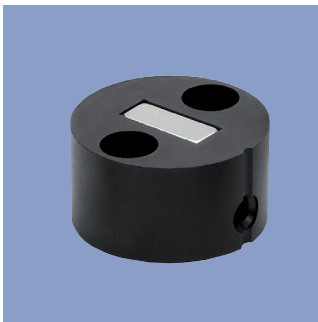

Z-RFC-P08

Position marker for fixation with threaded pin M5 (included in delivery)

- max. permitted radial offset ± 3 mm
- packaging unit:
1 pc. P/N 400056070
25 pcs. P/N 400056084

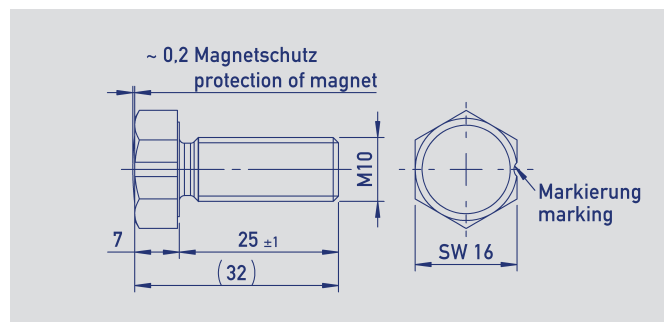
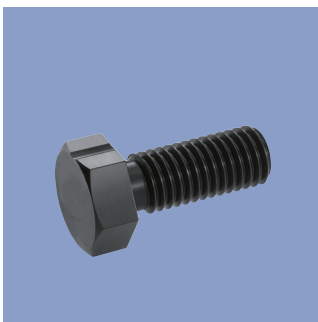

Z-RFC-P18

Screw position marker M10 x 25 mm, similar DIN 933, anodized aluminum, magnet potted

- max. permitted radial offset ± 3 mm
- packaging unit:
1 pcs. P/N 400104756
25 pcs. P/N 400104757

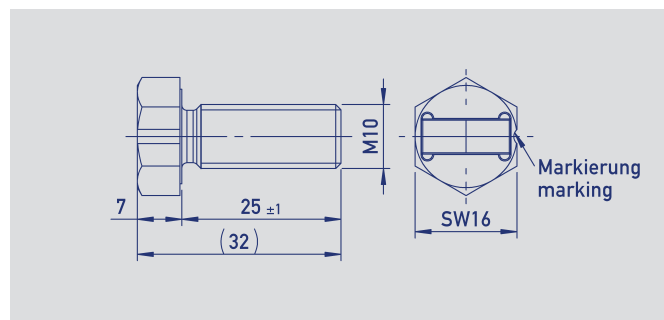
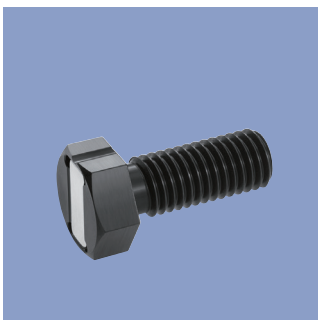

Z-RFC-P20

Screw position marker M10 x 25 mm, similar DIN 933, anodized aluminum

- max. permitted radial offset ± 3 mm
- packaging unit:
1 pcs. P/N 400104758
25 pcs. P/N 400104759

Position Marker Mounting Material

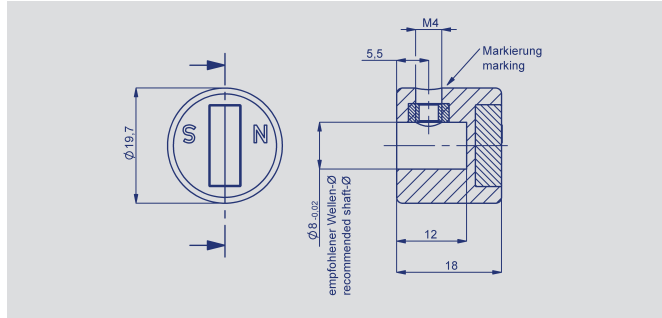

Z-RFC-P23

Position marker for fixation with threaded pin M4 (included in delivery)

- max. permitted radial offset ± 3 mm
- packaging unit:
1 pcs. P/N 400056074
100 pcs. P/N 400056085

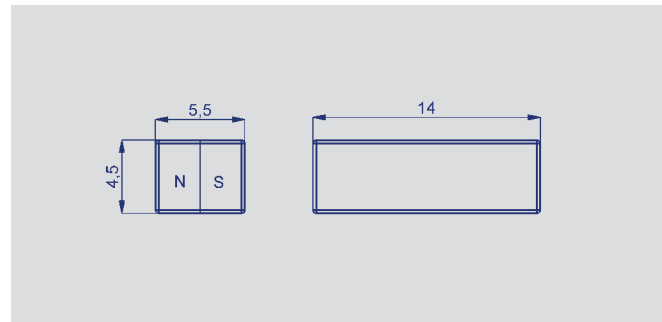

Z-RFC-P04

Magnet for direct application onto customer's shaft

- max. permitted radial offset ± 3 mm
- packaging unit:
1 pc. P/N 40005659
50 pcs. P/N 400056082

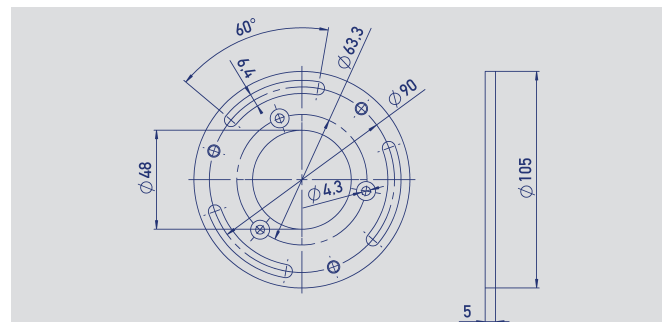
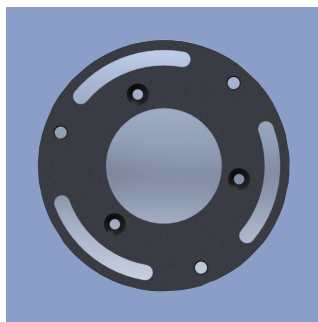

Z-RFX-M01

Mounting plate for adjustable mounting on screw-hole 90 mm

- aluminum, anodized
 - P/N 400104278
- Assembly material (3 x countersink screw) included in delivery

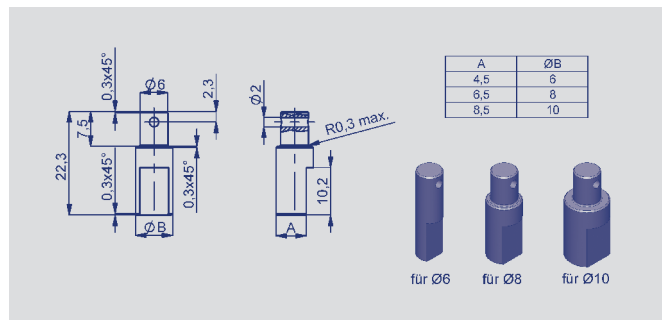

Z-RFC-S01 / Z-RFC-S02 / Z-RFC-S03

Shaft adapter for Z-RFC-P02.

Fixation at position marker with locking pin.

- Z-RFC-S01: Ø 6 mm, P/N 400056206
- Z-RFC-S02: Ø 8 mm, P/N 400056207
- Z-RFC-S03: Ø 10 mm, P/N 400056208



Working distances (mm)

Interfaces	Z-RFC-P02 / -P04 / -P08 / -P20 / -P23	Z-RFC-P18
Analog (current)	0.3 ... 3.5	0 ... 2.5
CANopen one-channel	0.8 ... 4	0 ... 3
CANopen two-channel	0.3 ... 3.5	0 ... 2.5

Mounting instructions Z-RFC-P04

- In general, we recommend mounting on not magnetizable materials, otherwise the stated working distances can change
- If the shaft is magnetizable please keep sufficient distance
- When the magnet is mounted in the shaft, the shaft may not be magnetizable
- If the magnet is axially fixed on a magnetizable shaft the working distances reduces by approx. 20%

Lateral magnet offset

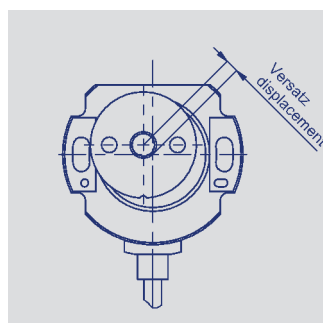

Lateral magnet offset will cause additional linearity error. The angle error, which is caused by radial displacement of sensor and position marker depends on the used position marker or magnet type.

Additional error (°) at radial displacement

Interface	Z-RFC-P02 / P04 / P08 / P20 / P23			Z-RFC-P18		
	0.5 mm	1 mm	2 mm	0.5 mm	1 mm	2 mm
Analog (current)	0.7	1.8	5.2	1.1	2.0	4.6
CANopen one-channel	0.4	1.1	3.5	0.7	1.3	3.3
CANopen two-channel	0.7	1.8	5.2	1.1	2.0	4.6

Accessories
Connector System M12

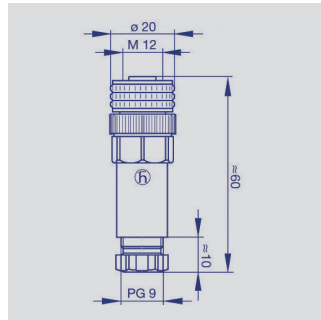

Pin assignment

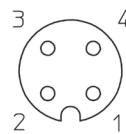

M12x1 Mating female connector, 4-pin, straight, A-coded, with coupling nut, screw termination, IP67, not shielded

Connector housing	Plastic PBT -25 °C...+90 °C
-------------------	--------------------------------

For wire gauge	6...8 mm, max. 0.75 mm ²
----------------	-------------------------------------

Type	EEM 33-88, P/N 400005633
------	--------------------------

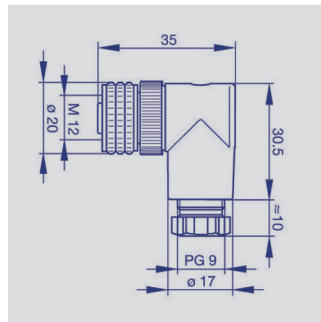

Pin assignment

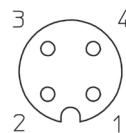

M12x1 Mating female connector, 4-pin, angled, A-coded, with coupling nut, screw termination, IP67, not shielded

Connector housing	Plastic PBT -25 °C...+90 °C
-------------------	--------------------------------

For wire gauge	6...8 mm, max. 0.75 mm ²
----------------	-------------------------------------

Type	EEM 33-89, P/N 400005634
------	--------------------------

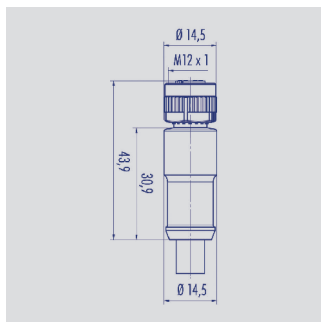

Pin assignment

- 1 = brown
- 2 = white
- 3 = blue
- 4 = black

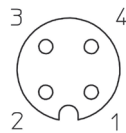

M12x1 Mating female connector, 4-pin, straight, A-coded, with molded cable, not shielded, IP67, open ended

Connector housing	Plastic PA
-------------------	------------

Cable sheath	PUR; Ø = max. 6 mm, -40 °C...+85 °C (fixed)
--------------	--

Wires	PP, 0.34 mm ²
-------	--------------------------

Length	Type	P/N
2 m	EEM 33-35	400056135
5 m	EEM 33-36	400056136
10 m	EEM 33-37	400056137

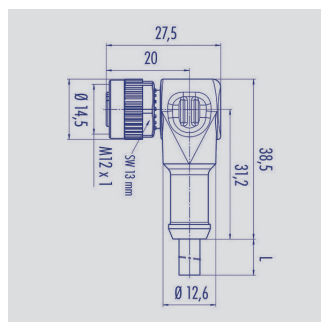

Pin assignment

- 1 = brown
- 2 = white
- 3 = blue
- 4 = black

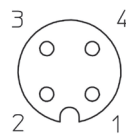

M12x1 Mating female connector, 4-pin, angled, A-coded, with molded cable, not shielded, IP67, open ended

Connector housing	Plastic PA
-------------------	------------

Cable sheath	PUR; Ø = max. 6 mm, -40 °C...+85 °C (fixed)
--------------	--

Wires	PP, 0.34 mm ²
-------	--------------------------

Length	Type	P/N
2 m	EEM 33-38	400056138
5 m	EEM 33-39	400056139
10 m	EEM 33-40	400056140

Accessories
Connector System M12

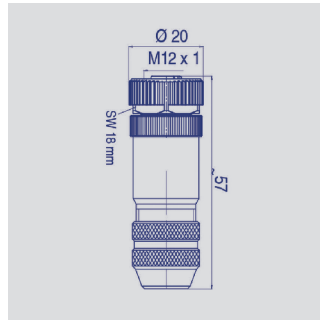

Pin assignment

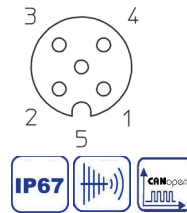

M12x1 Mating female connector, 5-pin, straight, A-coded, with coupling nut, screw termination, IP67, shielded, CAN-bus

Connector housing Metall
-40 °C...+85 °C

For wire gauge 6...8 mm, max. 0.75 mm²

Type EEM 33-73, P/N 005645

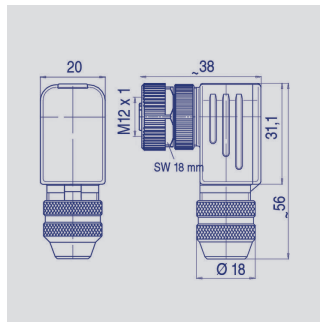

Pin assignment

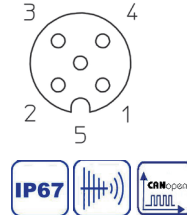

M12x1 Mating female connector, 5-pin, angled, A-coded, with coupling nut, screw termination, IP67, shielded, CAN-Bus

Connector housing Metall
-40 °C...+85 °C

For wire gauge 6...8 mm, max. 0.75 mm²

Type EEM 33-75, P/N 005646

It is possible to turn and fix the contact carrier in 90° positions.

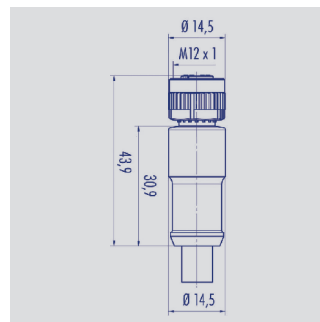

Pin assignment

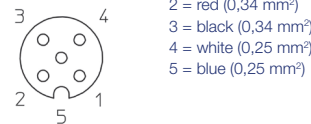

M12x1 Mating female connector, 5-pin, straight, A-coded, with molded cable, IP67, shielded, open ended, CAN-Bus

Connector housing PUR

Cable sheath PUR Ø = max. 7.2 mm,
-25 °C...+85 °C (moved)

Wires PP 2x 0.25 mm²
+ 2 x 0.34 mm²

Length	Type	P/N
2 m	EEM 33-41	056141
5 m	EEM 33-42	056142
10 m	EEM 33-43	056143

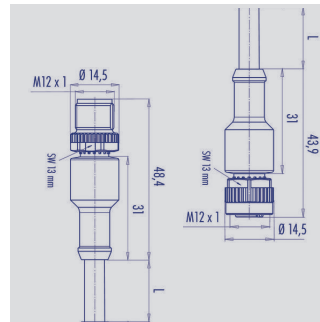

Pin assignment

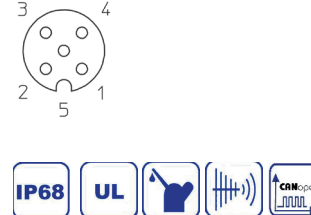

M12x1 Mating female connector, 5-pin, straight, A-coded, with molded cable, IP68, CAN-Bus

Connector housing PUR

Cable sheath PUR; Ø 7.2 mm
-25 °C... +85 °C (fixed)

Length	Type	P/N
5 m	EEM 33-44	056144

IP67 Protection class to DIN EN 60529
IP68 Schutzart IP68 nach DIN EN 60529

CANopen CAN-bus
UL UL - approved

UL Very good resistance to oils, coolants und lubricants
EMC Very good Electromagnetic Compatibility (EMC) and shield systems

Note: The protection class is valid only in locked position with its plugs. The application of these products in harsh environments must be checked in particular cases

Novotechnik U.S., Inc.
155 Northboro Road
Southborough, MA 01772
Phone 508 485 2244
Fax 508 485 2430
info@novotechnik.com
www.novotechnik.com

© 11/2017
Printed in Germany.

The specifications contained in our datasheets are intended solely for informational purposes. The documented specification values are based on ideal operational and environmental conditions and can vary significantly depending on the actual customer application. Using our products at or close to one or more of the specified performance ranges can lead to limitations regarding other performance parameters. It is therefore necessary that the end user verifies relevant performance parameters in the intended application. We reserve the right to change product specifications without notice.