

**NOVOHALL
Rotary Sensor
non-contacting**

Series RSB-3600
Series RMB-3600

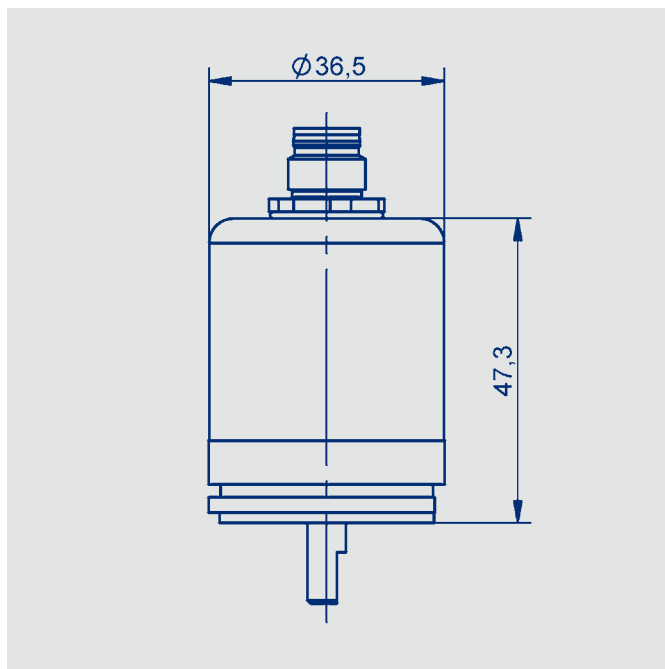

Special features

- Non-contacting, hall technology
- Measuring range up to 5760°
- Single- and multiturn
- True-Power-On system: counts turns even when not powered. Patented non-volatile technology does not require gears or batteries
- Solid shaft or hollow shaft
- Protection class IP67, IP6K9K
- Optimized for industrial and mobile applications
- Resolution 12 bit (singleturn) or up to 18 bit (multiturn)
- Absolute linearity up to $\pm 0.03\%$
- One and multi-channel versions

Applications

- Mechanical engineering
 - Textile machinery
 - Packing machinery
 - Sheet metal and wire working machinery
- Medical appliances
- Mobile machinery
 - Industrial trucks
 - Construction machinery
 - Agricultural and forestry machinery
- Navy applications

Non-contacting Rotary Sensor in very robust design including a double bearing system in a compact OD 36 mm full metal housing.

The sensor is based on the Hall technology and the True-Power-On multiturn additionally utilizes the GMR technology (Giant Magneto Resistance) for measurements of up to 16 revolutions.

The heavy-duty version in IP6K9K ingress protection version is well suited for extreme environment applications including high bearing loads.

The semi-hollow shaft version with its integrated stator coupling obsoletes a costly

separate shaft coupling. Versions with an industry standard M12-connector or cable in different lengths are available.

There is a wide variety of analog and digital electrical interfaces to choose from.

Contents

Dimension drawing	3
Mechanical data	4
	5
Singleturn RSB-3600	6
Output Characteristics	
Technical data analog versions	7
Ordering specifications analog versions	8
Technical data digital versions	9
Ordering specifications digital versions	10
Multiturn RSM-3600	
Output Characteristics	
Technical data analog versions	11
Ordering specifications analog versions	13
Technical data digital versions	14
Ordering specifications digital versions	15
Accessories	
Shaft couplings	16
M12 connector system	17
Signal processing	18

Dimension Drawing

RSB/RMB-3601
Ø 6 mm shaft

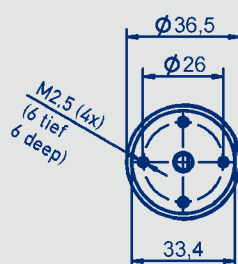

RSB/RMB-3624
Ø 10 mm shaft heavy duty



RSB/RMB-3607
Ø 6 mm hollow shaft

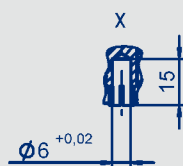
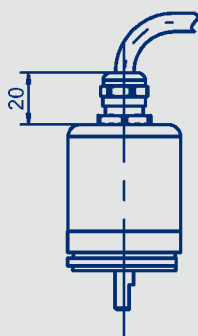
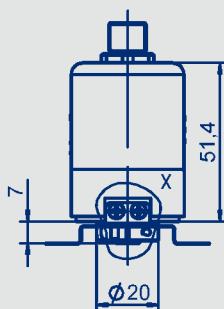
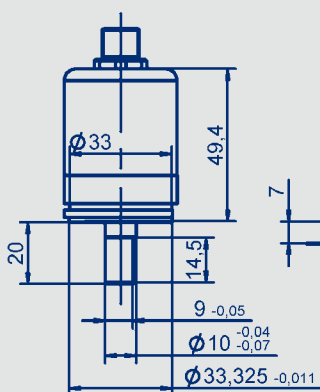
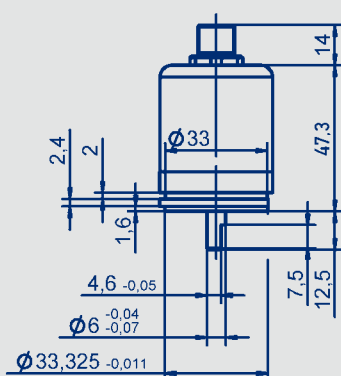
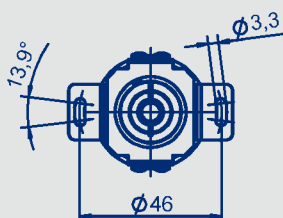

Installation dimensions
for mating shaft.

Mounting clamp

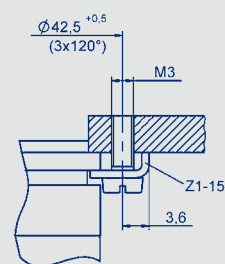

Pin assignment M12, 4 pin

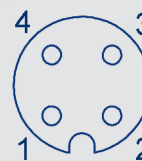

A-coded

Pin assignment M12, 8 pin

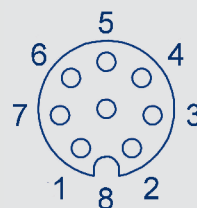

A-coded

CAD data see
www.novotechnik.de/en/download/cad-data/

Mechanical Data

Description	Ø 6 mm shaft RSB-/RMB3601- - - - -	Ø 10 mm shaft heavy duty RSB-/RMB3624- - - - -	Ø 6 mm hollow shaft RSB-/RMB3607- - - - -
Material	Flange: anodized aluminum, AlSiMgBi Cover: galvanized steel, St 12 1.0330 Shaft: stainless steel, X10CrNiS18-9 1.4305		Coupling: stainless steel, X10CrNi 18-8 1.4310
Electrical connections	Cable 4 x 0.5 mm ² , AWG 20, shielded, cable connection, length 1 m, 3 m, 5 m, 10 m Cable 4 x 2 x 0.25 mm ² , AWG 24, twisted pair, shielded, cable gland, length 1 m, 3 m, 5 m, 10 m Connector M12x1 4 pin / 8 pin		
Mechanical Data			
Dimensions	see dimension drawing		
Mounting	with 3 fixing clamps Z1-15 (included in delivery) or via frontal thread 4 x M3		Stator coupling
Mechanical travel	360 continuous		
Permitted operating speed (mechanical) *	12 000	6000	12 000 min ⁻¹
Bearing lifetime	100 million movements		
Permitted shaft load (axial / radial) static or dynamic	40 / 50	100 / 100	40 / 50 N
Torque @ RT 20 °C typ. **	0.3	3	0.5 Ncm
Weight (without connection)	ca. 100 g		
Vibration (IEC 60068-2-6)	5 ... 2000 A _{max} = 0.75 Hz a _{max} = 20 g		
Shock (IEC 60068-2-27)	50 (6 ms) g		
Protection class (ISO 20653)			
housing side	IP67	IP6K9K	IP67
shaft side	IP65	IP67	IP65
Operating temperature range	-30 ... +85 (connector), -40 ... +85 (cable), higher temperatures on request °C		
Operating humidity range	0 ... 98 (no condensation) % R.H.		

*) Multiturn sensor RMB: permitted operating speed with valid output signal max. 800 min⁻¹

***) Depending on the environmental temperature and standstill time, the necessary force for the initial operating of the shaft may increase

Output Characteristics Singleturn

One-channel, cw

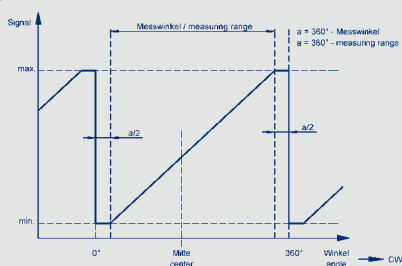

One-channel, ccw

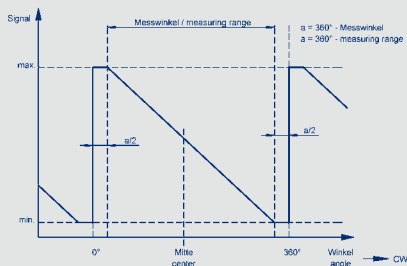

Two channels, crossed characteristics, channel 1 cw

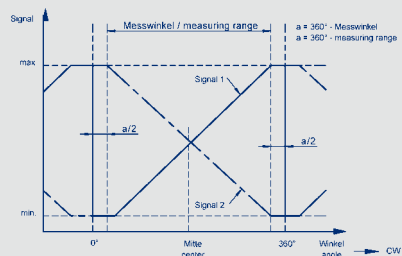

On request: Two channels, signal 2 = 0.5 x signal 1

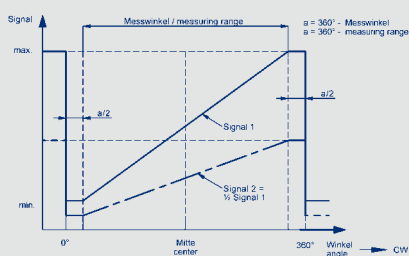

On request: Trapezoid output characteristics

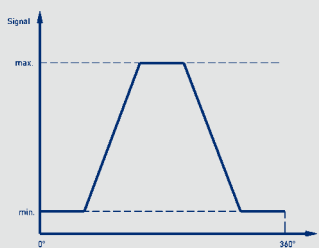

On request: Different gradients

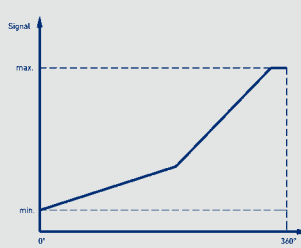

On request: 2 offset output characteristics

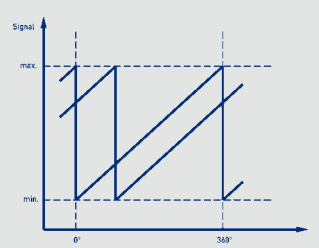

On request: Parabolic output characteristic

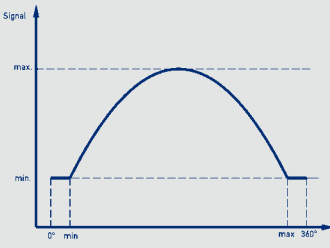

Technical Data
Analog Versions
- Voltage
- Current
Singleturn RSB-3600

Type Designations	RSB-3601- ____ - 2 ____ - ____ Ratiometric	RSB-3601- ____ - 1 1 ____ - ____ Analog voltage	RSB-3601- ____ - 1 2 ____ - ____ Analog current	
Electrical Data				
Output signal	ratiometric to supply voltage 0.25 ... 4.75 V 0.5 ... 4.5 V (load ≥ 1 k Ω)	0.1 ... 10 V (load ≥ 10 k Ω)	4 ... 20 mA (burden ≤ 500 Ω)	
Number of channels	1 / 2	1	1	
Update rate	typical 5			kHz
Resolution	12			Bit
Measuring range	0 ... 30 up to 0 ... 360 (10°-steps)			°
Absolute linearity at measuring range 360°	≤ 0.8			$\pm\%$ FS
Repeatability	≤ 0.1			°
Hysteresis	≤ 0.1			°
Temperature error at measuring range 360°	≤ 0.6	≤ 1.6	≤ 1.9	$\pm\%$ FS
Supply voltage U_b	5 (4.5 ... 5.5)	24 (18 ... 30)	24 (18 ... 30)	VDC
Current consumption (w/o load)	typical 15 (typ. 8 on request) per channel			mA
Reverse voltage	yes, supply lines			
Short circuit protection	yes (vs. GND and supply voltage)			
Insulation resistance (500 VDC)	≥ 10			M Ω
Cross-section cable	4 pole: 0.5 (AWG 20), 8 pole: 0.25 (AWG 24)			mm ²
Environmental Data				
MTTF (DIN EN ISO 13849-1 parts count method, w/o load, wc)	356 (one-channel) 210 (per channel) partly redundant 388 (per channel) fully redundant	107	105	years years years
Functional safety	If you need assistance in using our products in safety-related systems, please contact us			
EMC compatibility	EN 61000-4-2 Electrostatic discharge (ESD) 4 kV, 8 kV EN 61000-4-3 Electromagnetic fields 10 V/m EN 61000-4-4 Fast transients (Burst) 1 kV EN 61000-4-6 Conducted disturbances, induced by RF-fields 10 V eff. EN 61000-4-8 Power frequency magnetic fields 30 A/m EN 55016-2-3 Radiated disturbances class B			

Connection assignment

One-channel versions

Signal	Cable code B4_	Connector M12 code FM4	Connector with cable (see accessories)
Supply voltage U_b	BN	pin 1	BN
Signal output	GN	pin 2	WH
GND	WH	pin 3	BU
Not assigned	YE	pin 4	BK
Shield	shield	shield	-

Partly redundant versions

Signal	Cable code B4_	Connector M12 code FM4	Connector with cable (see accessories)
Supply voltage U_b	BN	pin 1	BN
Signal output 1	GN	pin 2	WH
GND	WH	pin 3	BU
Signal output 2	YE	pin 4	BK
Shield	shield	shield	-

Fully redundant versions

Signal	Cable code B8_	Connector M12 code FM8	Connector with cable (see accessories)
GND 1	WH	pin 1	WH
Supply voltage U_b	BN	pin 2	BN
Signal output 1	GN	pin 3	GN
Not assigned	YE	pin 4	YE
Signal output 2	GY	pin 5	GY
Not assigned	PK	pin 6	PK
GND 2	BU	pin 7	BU
Supply voltage U_b	RD	pin 8	RD

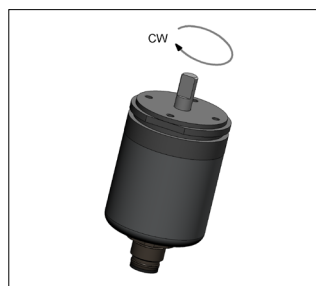

When the shaft marking is pointing towards the flattening on the housing flange, the sensor output is near of the electrical center position.

Ordering Specifications
Analog Versions
- Voltage
- Current
Singleturn RSB-3600

Ordering specifications

Preferred types printed in bold

Supply voltage

- 1: 24 V (18 ... 30 V)
- 2: 5 V (4.5 ... 5.5 V)

Output signal at supply voltage = 24 V

- 1: 0.1 ... 10 V
- 2: 4 ... 20 mA

Output signal at supply voltage = 5 V

- 1: 0.25 ... 4.75 V ratiometric to supply voltage
- 2: 0.5 ... 4.5 V ratiometric to supply voltage

Output characteristics

- 1: Rising cw
- 2: Rising ccw
- 3: Crossed outputs channel 1 rising cw (partly redundant)
- 4: Crossed outputs channel 1 rising cw (fully redundant)

Electrical connection cable

Single and partly redundant, cable, 4 pole, shielded

B41: L = 1 m

B43: L = 3 m

B45: L = 5 m

B40: L = 10 m

Fully redundant, cable, 8 pole, shielded

B81: L = 1 m

B83: L = 3 m

B85: L = 5 m

B80: L = 10 m

Electrical connection connector

FM4: M12x1, 4 pin, single and partly redundant

FM8: M12x1, 8 pin, fully redundant

R S B - 3 6 0 1 - 6 3 6 - 2 1 1 - F M 4

Measuring range

03: Measuring range 0° ... 30° min.

...

06, 12, 18, 24, 36

...

36: Measuring range 0° ... 360° max.
other angles on request

Number of channels

6: Single (1x supply voltage; 1x output)

7: Partly redundant (1x supply voltage ; 2x output) (only supply voltage = 5 V)

8: Fully redundant (2x supply voltage; 2x output) (only supply voltage = 5 V)

Series

RSB-3600 (Singleturn)

Mechanical version

3601: Synchro flange, shaft \varnothing 6 mm x 12.5 mm

3624: Synchro flange, heavy duty version, shaft \varnothing 10 mm x 20 mm

3607: Round flange, hollow shaft \varnothing 6 mm

Other flange and shaft designs on request

Technical Data Incremental Interface Singleturn RSB-3600

Type Designations	RSB-36_ _-2_ _-51_ _- _ _ _ _ Supply voltage 5 VDC		
Electrical Data			
Outputs	A+ / A- B+ / B- Z+ / Z-		
Level	RS-422, TTL-compatible		
Length Z-pulse	Distance between 2 edges A / B		
Pulses per revolution	1024, other resolutions see page 12		ppr
Counts per revolution (after quadrature)	4096		
Option Low Speed			
- Minimum edge separation	8		µs
- Minimum input frequency of counter input	32		kHz
- Maximum operational speed	1 800		min ⁻¹
Option High Speed			
- Minimum edge separation	0.5		µs
- Minimum input frequency of counter input	500		kHz
- Maximum operational speed	Limited due to rotation speed of bearing (see mechanical data)		
Measuring range	360		
Absolute linearity	≤ 1		±% FS
Repeatability	≤ 0.1		°
Hysteresis	≤ 0.7		°
Temperature error	≤ 0.375		±% FS
Supply voltage Ub	5 (4.5 ... 5.5)		VDC
Current consumption (w/o load)	typical 20		mA
Reverse voltage	yes, supply lines and outputs		
Short circuit protection	yes, (vs. GND and supply voltage)		
Ohmic load at outputs	≥ 120 per channel A / B / Z		Ω
Insulation resistance (500 VDC)	≥ 10		MΩ
Cross-section Cable	0.25 (AWG 24)		mm ²
Environmental Data			
MTTF (DIN EN ISO 13849-1 parts count method, w/o load, wc)	246		years
Functional safety	If you need assistance in using our products in safety-related systems, please contact us		
EMC compatibility	EN 61000-4-2 Electrostatic discharge (ESD) 4 kV, 8 kV EN 61000-4-3 Electromagnetic fields 10 V/m EN 61000-4-4 Fast transients (Burst) 1 kV EN 61000-4-6 Conducted disturbances, induced by RF fields 10 V eff. EN 61000-4-8 Power frequency magnetic fields 30 A/m EN 55016-2-3 Radiated disturbances class B		



Connection assignment

Signal	Cable code B8_	Connector M12 code FM8	Connector with cable (see accessories)
GND	WH	pin 1	WH
Supply voltage Ub	BN	pin 2	BN
A+	GN	pin 3	GN
A-	YE	pin 4	YE
B+	GY	pin 5	GY
B-	PK	pin 6	PK
Z+	BU	pin 7	BU
Z-	RD	pin 8	RD

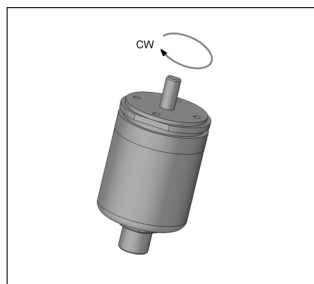

When the shaft marking is pointing away from the flattening on the housing flange, the sensor is at reference pulse (Z).
Rotational direction cw: A leads before B.

Technical Data
Incremental Interface
Singleturn RSB-3600

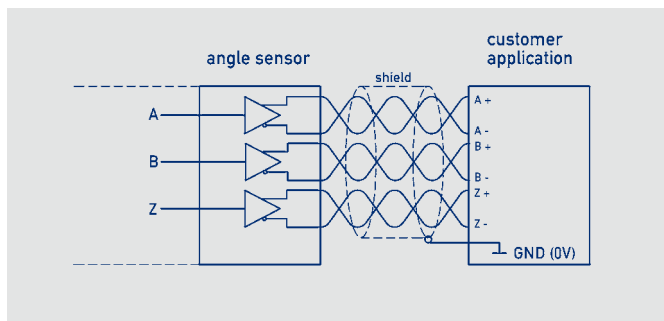
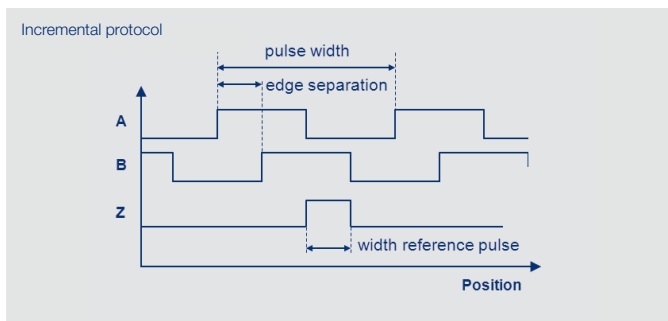

Electrical Data

Pulses per revolution	1024	512	256	128	ppr
Counts per revolution (after quadrature)	4096	2048	1024	512	
Option Low Speed					
- Minimal edge separation	8				μs
- Minimum input frequency of counter input	32	32	32*	32*	kHz
- Maximum operational speed	1800	3600	7200**	14400**	min^{-1}
Option High Speed					
- Minimal edge separation	0.5				μs
- Minimum input frequency of counter input	500	500	500*	105*	kHz
- Maximum operational speed	see note **				

*) The requirement for the minimum input frequency of counter input is reduced at lower speed (see charts below)

**) Maximum operating speed is limited by maximum rotation speed of bearing (see Mechanical Data)

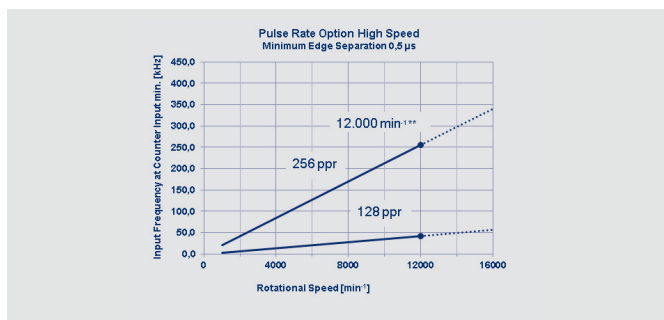
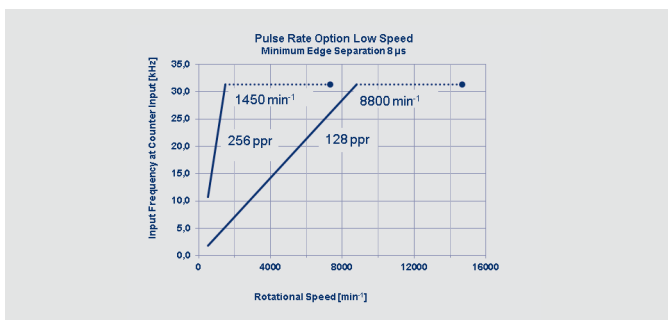

Ordering Specifications
Digital Versions
- Incremental
Singleturn RSB-3600

Ordering specifications

Preferred types printed in bold

Interface

5: Incremental interface A / B / Z

Interface parameters for Incremental Interface

Low Speed Mode (Minimum edge separation 8 µs)

15: 5 V (4.5 ... 5.5 V) supply voltage, output RS422, TTL-compatible

High Speed Mode (Minimum edge separation 0.5 µs)

10: 5 V (4.5 ... 5.5 V) supply voltage, output RS422, TTL-compatible

24 V supply voltage on request.

UWV signals instead of ABZ signals for motor commutation on request

Absolute position at Power On (Power on Burst) on request

High side and low side outputs on request.

Electrical connection cable

B81: L = 1 m

B83: L = 3 m

B85: L = 5 m

B80: L = 10

Electrical connection connector

FM8: M12x1

R S B - 3 6 0 1 - 2 1 2 - 5 1 5 - F M 8

Series

RSB-3600 (Singleturn)

Resolution Incremental interface 5 _ _

12: 1024 ppr - 4096 counts (after quadrature)

11: 512 ppr - 2048 counts (after quadrature)

10: 256 ppr - 1024 counts (after quadrature)

09: 128 ppr - 512 counts (after quadrature)

Other resolutions on request

Interface

2: Digital Interface

Mechanical version

3601: Synchro flange, shaft Ø 6 mm x 12.5 mm

3624: Synchro flange, heavy duty version, shaft Ø 10 mm x 20 mm

3607: Round flange, hollow shaft Ø 6 mm

Other flanges and shaft designs on request

Output Characteristics Multiturn

Output signals measuring range 2 ... 14 turns

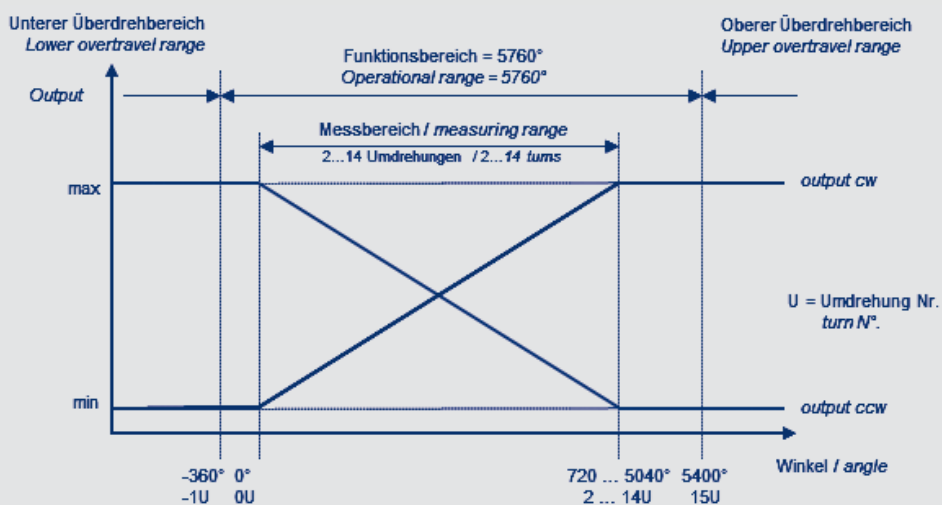

Output signals measuring range 15 ... 16 turns

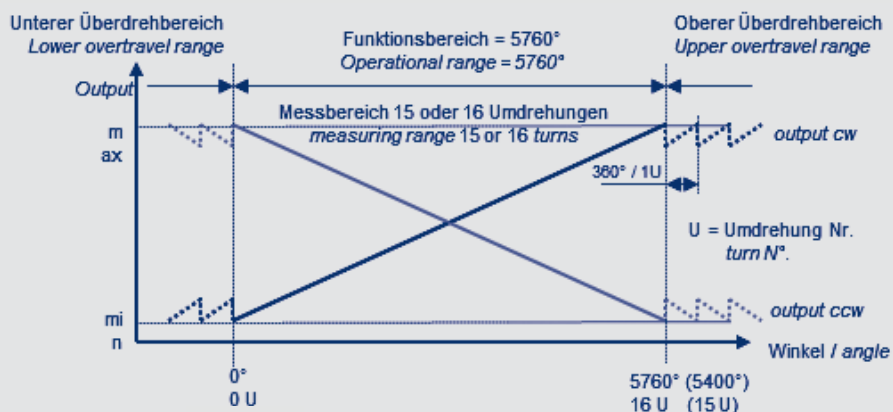

Technical Data
Analog Versions
- Voltage
- Current
Multiturn RMB-3600

Type Designations	RMB-3601-____-2____-____	RMB-3601-____-11____-____	RMB-3601-____-12____-____													
	Ratiometric	Analog voltage	Analog current													
Electrical Data																
Output signal	ratiometric (load $\geq 10\text{ k}\Omega$)	0.1 ... 10 V (load $\geq 10\text{ k}\Omega$)	4 ... 20 mA (burden $\leq 500\ \Omega$)													
Number of channels	1 / 2	1 / 2	1													
Resolution	16		bit													
Start time	typical 10		ms													
Response time	≤ 2		ms													
Measuring range	0 ... 720 up to 0 ... 5760 (360°-steps)		°													
Linearity	see table below															
Repeatability	≤ 0.5		°													
Hysteresis	≤ 1		°													
Temperature error	≤ 0.15	≤ 0.31	≤ 0.625 $\pm\%$ FS													
Supply voltage U_b	5 (4.5 ... 5.5)	24 (18 ... 30)	24 (18 ... 30) VDC													
Current consumption (w/o load)	typical 30		mA													
Reverse voltage	yes, supply lines and outputs															
Short circuit protection	yes (vs. GND and supply voltage)															
Insulation resistance (500 VDC)	≥ 10		M Ω													
Cross-section cable	0.5 (AWG 20)		mm ²													
Environmental Data																
MTTF (DIN EN ISO 13849-1 parts count method, w/o load, wc)	175 one-channel 175 (per channel) redundant	184 one-channel 184 (per channel) redundant	186 one-channel years years													
Functional safety	If you need assistance in using our products in safety-related systems, please contact us															
EMC compatibility	EN 61000-4-2 Electrostatic discharge (ESD) 4 kV, 8 kV EN 61000-4-3 Electromagnetic fields 10 V/m EN 61000-4-4 Fast transients (Burst) 1 kV EN 61000-4-6 Conducted disturbances, induced by RF fields 10 V eff. EN 61000-4-8 Power frequency magnetic fields 30 A/m EN 55016-2-3 Radiated disturbances class B															
Linearities																
Measuring range	2	3	4	5	6	7	8	9	10	11	12	13	14	15	16	Turns
Absolute linearity max.	0.5	0.417	0.375	0.350	0.333	0.321	0.313	0.306	0.300	0.295	0.292	0.288	0.286	0.283	0.281	$\pm\%$ FS
Independent linearity typ.	0.250	0.167	0.125	0.100	0.083	0.071	0.063	0.056	0.050	0.045	0.042	0.039	0.036	0.033	0.031	$\pm\%$ FS
Independent linearity max.	0.350	0.267	0.225	0.200	0.183	0.171	0.163	0.156	0.150	0.145	0.142	0.138	0.136	0.133	0.131	$\pm\%$ FS



Copnnection assignment

One-channel versions			
Signal	Cable code B4_	Connector M12 code FM4	Connector with cable (see accessories)
Supply voltage U_b	BN	pin 1	BN
Signal output	GN	pin 2	WH
GND	WH	pin 3	BU
Not assigned	YE	pin 4	BK
Shield	shield	shield	-

Redundant versions			
Signal	Cable code B4_	Connector M12 code FM4	Connector with cable (see accessories)
Supply voltage U_b	BN	pin 1	BN
Signal output 1	GN	pin 2	WH
GND	WH	pin 3	BU
Signal output 2	YE	pin 4	BK
Shield	shield	shield	-

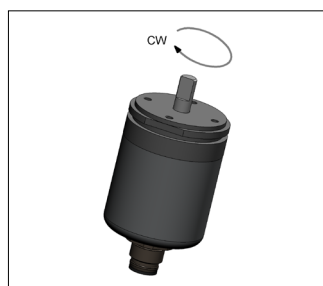

When the shaft marking is pointing towards the flattening on the housing flange, the sensor is located on an integer turn position.

Ordering Specifications
Analog Versions
- Voltage
- Current
Multiturn RMB-3600

Ordering specifications

Preferred types printed in bold

Supply voltage

- 1: 24 V (18 ... 30 V)
- 2: 5 V (4.5 ... 5.5 V)

Output signal at supply voltage = 5 V

- 1: 0.25 ... 4.75 V ratiometric
- 2: 0.5 ... 4.5 V ratiometric

Output signal at supply voltage = 24 V

- 1: 0.1 ... 10 V
- 2: 4... 20 mA (only one-channel)

Output characteristics

- 1: Rising cw
 - 2: Rising ccw
 - 3: Crossed outputs channel 1 rising cw (redundant)
- Other output characteristics on request

Electrical connection cable

- B41: L = 1 m
- B43: L = 3 m
- B45: L = 5 m
- B40: L = 10 m

Electrical connection connector

- FM4: M12x1

R M B - 3 6 0 1 - 0 1 0 - 2 1 1 - F M 4

Series

RMB-3600 (Multiturn)

Mechanical version

- 3601: Synchro flange, shaft \varnothing 6 mm x 12.5 mm
 - 3624: Synchro flange, heavy duty version, shaft \varnothing 10 mm x 20 mm
 - 3607: Round flange, hollow shaft \varnothing 6 mm
- Other flange and shaft designs on request

Number of turns for output characteristic

From 002 = 2 turns up to 016 = 16 turns, increment 1 turn

003, 006, 010, 016

Other measuring ranges on request

Technical Data
Digital Versions
- SSI
Multiturn RMB-3600

Type designations	RMB-36_ _-2_ _-44 _ - _ _ _ Supply voltage 24 VDC	
Electrical Data		
Protocol	SSI	
Inputs	RS422-compatible, CLK-lines via optocoupler galvanically isolated	
Monoflop time (tm)	20 ±1	µs
Coding	Gray, binary	
Update rate (internal)	1	kHz
Resolution	16 or 18 across the entire measuring range	
Measuring range	see ordering specifications	
Absolute linearity	14 turns: ≤ 0.036	±% FS
	16 turns: ≤ 0.031	±% FS
Repeatability	≤ 0.5	°
Hysteresis	≤ 1	°
Temperature error	≤ 0.1	±% FS
Supply voltage Ub	24 (10 ... 32), (5 V on request)	
Current consumption (w/o load)	typical 10	
Reverse voltage	yes, supply lines and outputs	
Short circuit protection	yes (vs. GND, max. 1 min)	
Ohmic load at outputs	≥ 120	Ω
Maximum clock rate	1	MHz
Insulation resistance (500 VDC)	≥ 10	MΩ
Cross-section cable	0.25 (AWG 24)	
Environmental Data		
MTTF (DIN EN ISO 13849-1 parts count method, w/o load, wc)	173	Years
Functional safety	If you need assistance in using our products in safety-related systems, please contact us	
EMC compatibility	EN 61000-4-2 Electrostatic discharge (ESD) 4 kV, 8 kV EN 61000-4-3 Electromagnetic fields 10 V/m EN 61000-4-4 Fast transients (Burst) 1 kV EN 61000-4-6 Conducted disturbances, induced by RF fields 10 V eff. EN 61000-4-8 Power frequency magnetic fields 30 A/m EN 55016-2-3 Radiated disturbances class B	



Connection assignment

Signal	Cable code B8_	Connector M12 code FM8	Connector with cable (see accessories)
GND	WH	pin 1	WH
Supply voltage Ub	BN	pin 2	BN
CLK +	GN	pin 3	GN
CLK -	YE	pin 4	YE
Data +	GY	pin 5	GY
Data -	PK	pin 6	PK
Do not connect	BU	pin 7	BU
Do not connect	RD	pin 8	RD

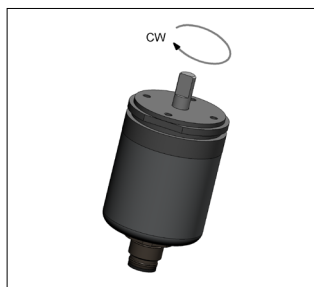

When the shaft marking is pointing towards the flattening on the housing flange, the sensor is located on an integer turn position.

Ordering Specifications
Digital Versions
Multiturn RMB-3600

Ordering specifications

Preferred types printed in bold

Interface

4: Synchronous Serial Interface (SSI)

Interface parameters SSI Interface

- 41: SSI 16 bit, Gray code, rising cw
- 43: SSI 25 bit (18 bit data), Gray code, rising cw
- 45: SSI 16 bit, binary code, rising cw
- 47: SSI 25 bit (18 bit data), binary code, rising cw

Electrical connection cable

- B81: L = 1 m**
- B83: L = 3 m**
- B85: L = 5 m
- B80: L = 10 m

Electrical connection connector

FM8: M12x1

R M B - 3 6 0 1 - 2 1 4 - 4 4 1 - F M 8

Series

RMB-3600 (Multiturn)

Mechanical version

- 3601: Synchro flange, shaft \varnothing 6 mm x 12.5 mm
- 3624: Synchro flange, heavy duty version, shaft \varnothing 10 mm x 20 mm
- 3607: Round flange, hollow shaft \varnothing 6 mm
- Other flanges and shaft designs on request

Number of turns for output characteristic

- 14: 14 turns = 5040°, measuring range controlled**
- 16: 16 turns = 5760°, measuring range not controlled

Interface

2: Digital interface

Shaft couplings

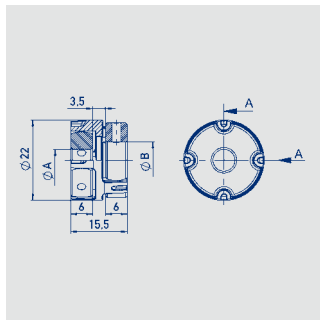
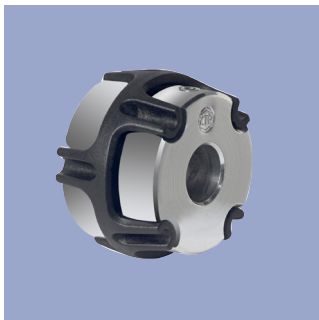

Shaft coupling for 6 up to 10 mm shaft diameters, backlash-free, double cardanic

Material	Aluminum, PEEK		
Max. torque	1 Nm		
Operating temperature	-40 ... +160° C		
Max. displacements	radial 0.1 mm, angular 0.45 °		
Mounting	2 threaded pins with internal hexagon		
Type	ØA	ØB	P/N
Z-106-G6	6	6	103910
Z-106-G-6,35	6	6,35	103912
Z-106-G10	6	10	103913

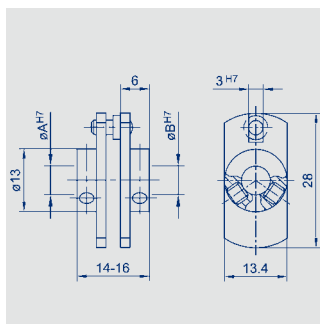
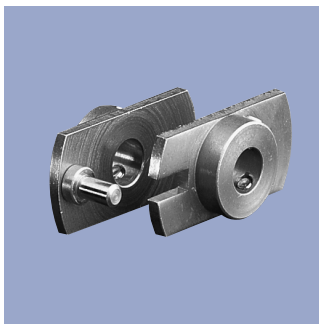

Fork coupling for 6 mm shaft diameters, low backlash

Material	stainless steel, ground driving pin		
Max. displacement	1 mm		
Mounting	2 fillister head screws M3 each with internal hexagon. Angle screwdriver SW 1.5 in delivery included.		
Type	ØA	ØB	P/N
Z-104-G-6	6	6	005690

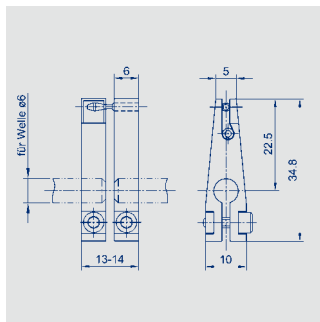

Fork coupling for 6 mm shaft diameters, backlash-free

Material	anodized aluminum, black, driving pin and spring hardened		
Max. displacement	1 mm		
Max. transferable torque	5 Ncm		
Mounting	1 fillister head screw M3 each with internal hexagon. Angle screwdriver SW 2.5 in delivery included.		
Type	P/N		
Z-105-G-6	005691		

Multifunctional Measuring Device with Display

Novotechnik U.S., Inc.
155 Northboro Road
Southborough, MA 01772
Phone 508 485 2244
Fax 508 485 2430
info@novotechnik.com
www.novotechnik.com

© 10/2016
Subject to changes.

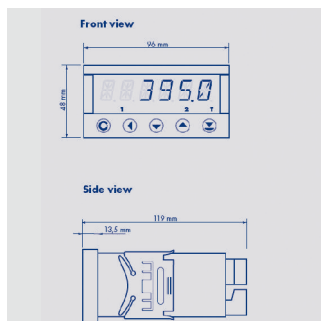

Special features

- Supply voltage 10 ... 30 VDC, 80 ... 250 V DC or AC
- high accuracy
- direct connection of potentiometric and standardized signals
- adjustable supply voltage for sensors 5 ... 24 V
- Temperature coefficient 100 ppm/K
- optional RS 232, RS 485, analog output, limited switch
- complete data see separate [data sheet MAP-4000](#)

Ordering specifications

Number comparator relays

0: none
2: 2 relays
4: 4 relays

Analog output

0: no analog output
1: analog output present

Interface

0: no interface
1: RS 232
2: RS 485

M A P - 4 0 1 0 - 0 0 0 - 1 0 1

Series

Supply voltage

00: 10 ... 30 V AC/DC
10: 80 ... 250 V AC

Adjustable supply voltage (5 ... 24 V / max. 1,2 W)

1: with supply voltage

Display colour

1: red

Data storage (only with interface)

0: not storage
1: RTC storage
2: FAST storage